

DDM 160 – speed is of the essence



High-performance dry offset lid
printing system with up to 8 colors

- // Maximum production efficiency
- // Excellent print quality
- // Automation for one-man operation
- // Simple operation and maintenance
- // Intelligent control:
No lid – no ink and no lid – no print



//polytype is a world-leading manufacturer of systems for direct printing of plastic cups and lids. //polytype machines combine innovative technology with extremely high reliability and user-friendly operation. Its international customers appreciate the modular expansion options of the machines.

//polytype is part of the Swiss wifag//polytype Group, which operates globally and has branches in Switzerland, Germany, Bulgaria, USA and Thailand. This alliance gives //polytype access to a broad technology base and guarantees a global and professional partnership for your success.

The //polytype DDM 160 is a lid printing system offering optimum production efficiency. The printing/inking unit is designed for outstanding print quality and meets the highest requirements.

During development, the focus was on fast and simple changeovers and ease of maintenance. As a result, the machine can handle small and medium batch sizes quickly and flexibly.

The graphic color display ensures a seamless interface between man and machine with status monitoring, production parameters and diagnostics.

All //polytype DDM 160 machines are designed to meet the latest CE safety regulations.

For every cup there is a lid ... to be printed

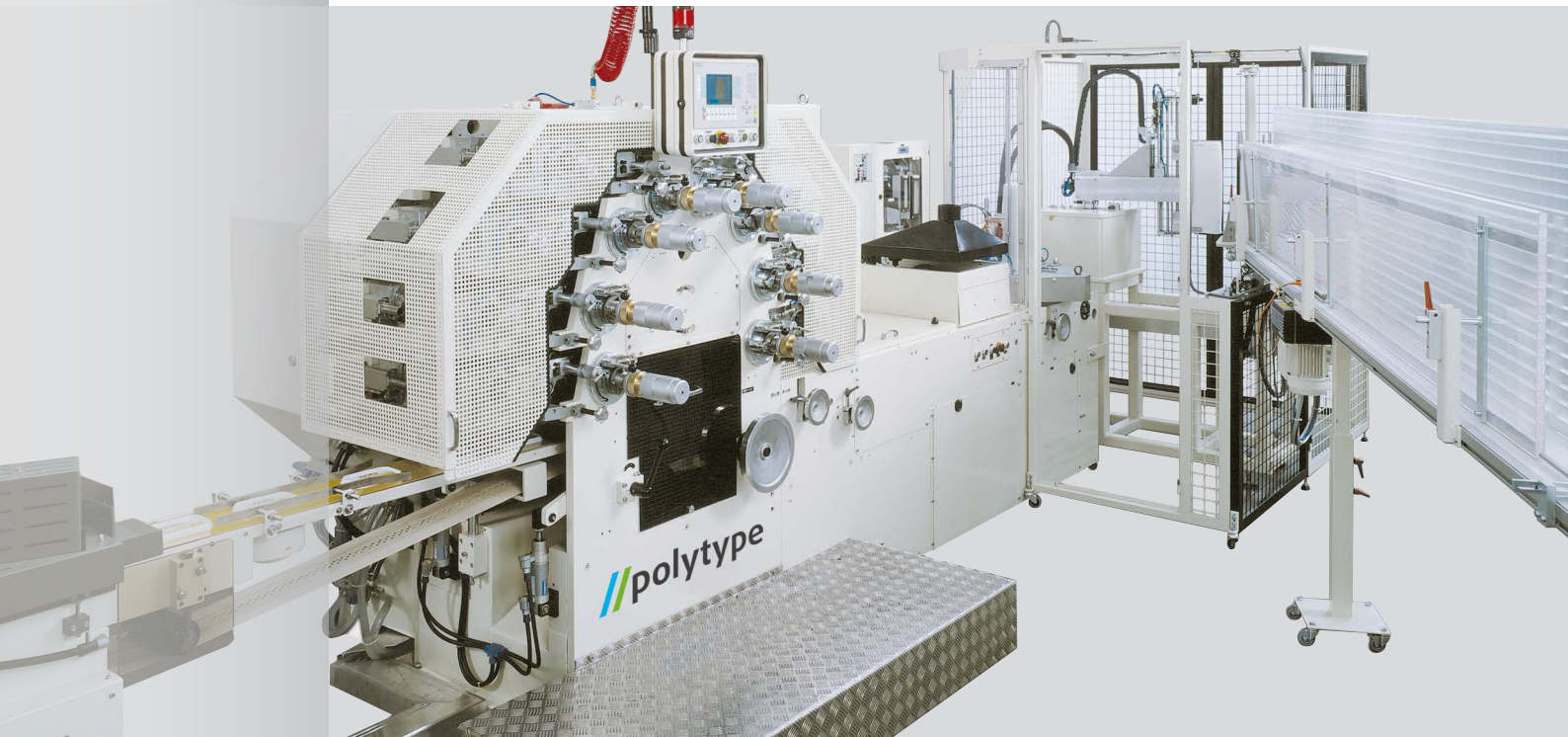

The //polytype DDM 160 is equipped with antighosting inking units with an ink agitator and leakfree ink fountains that can be removed quickly. A separate drive makes for quick and easy automatic roller cleaning and pre-inking. Ductor roll cooling is available as standard, oscillator roll cooling as an option.

Progressively adjustable ink metering via a display panel enables a controlled ink flow for excellent full-area and halftone print results.

The standard built-in, withdrawable printing plate cylinder offers good access for washing and changing the blanket. It is equipped with a quick-locking device and micro-setting for the register. It also has a fast changeover system for the printing segments. The standard equipment also includes twin-bearing supports on the counter-pressure roll.

- // Cooling facilities for ductor and oscillating rollers
- // Servo-driven lid stacking for exact timing
- // Excellent accessibility and operation from one side only
- // Data storage for reference data

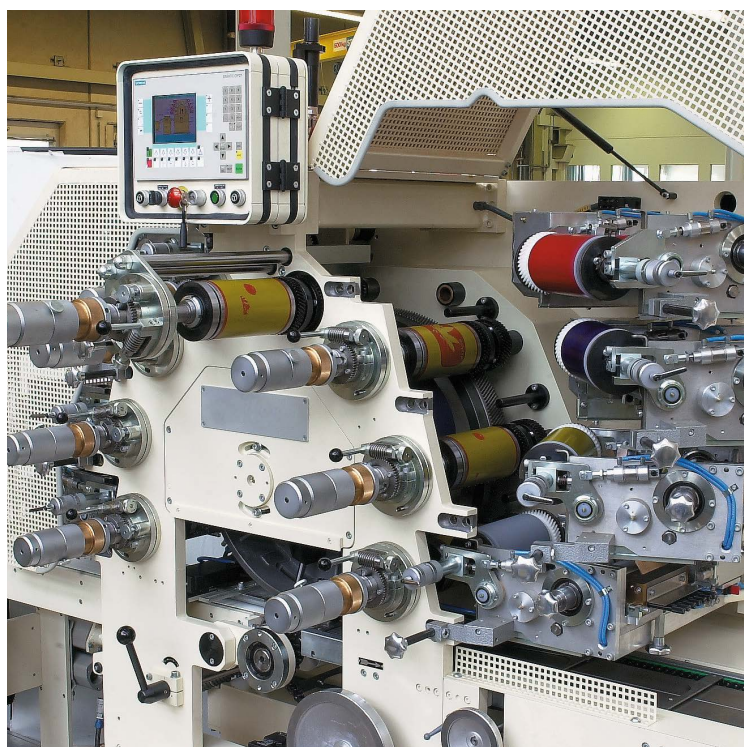

The //polytype DDM 160 ensures quick and easy format changes thanks to its excellent accessibility. One-man operation is supported by an infeed robot comprising conveyor belt, feed module and multi-stack elevator. Tooling changes on the feeding scrolls are also made easier thanks to the automatic lift-up scroll feeder.

The feed table is also equipped with central height adjustment and an integrated cooling plate.

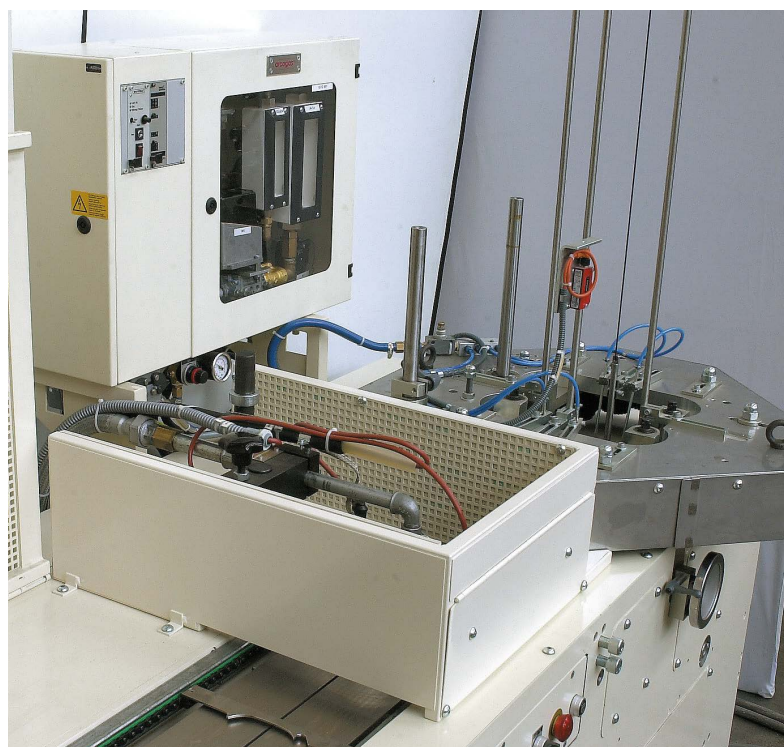

Gas pre-treatment with a preset, automatically adjusted gas/air mixture ensures the perfect preparation of the print areas. The gas pre-treatment has progressive flame control for propane, butane or natural gas. The intensity of the flame is regulated automatically by the machine speed.

The UV curing system has a 3-step switch (2/4/5.5 kW) and horizontal lid stacking with servo motor and multi-stack table.

The integrated lid counting device counts fed, ejected and stacked (printed) lids. There is an automatic lid blow-off device for scrap.

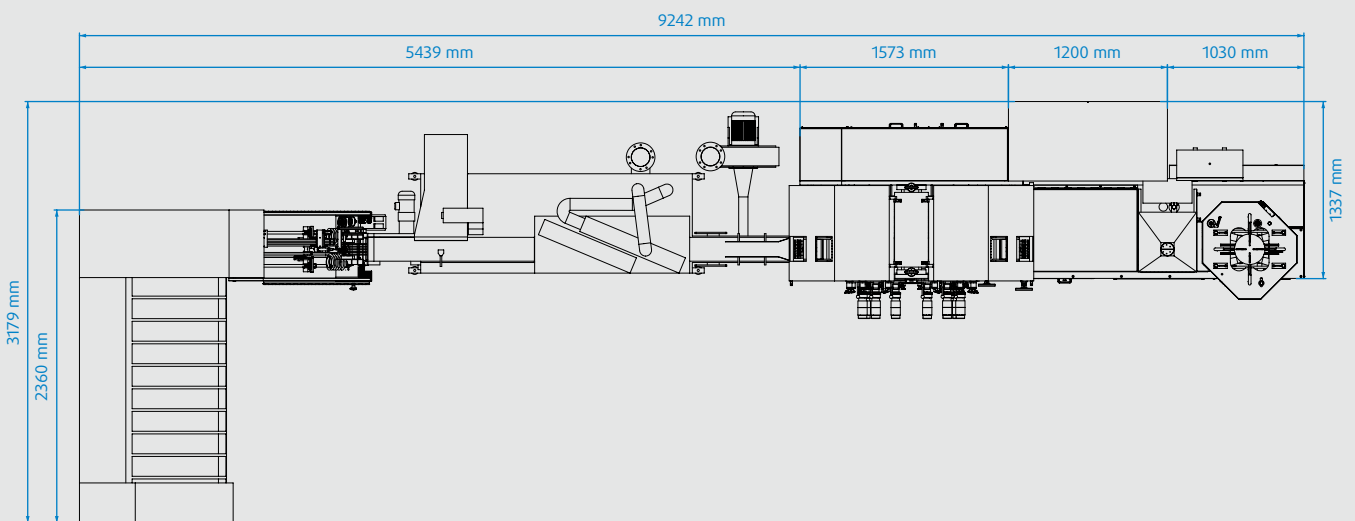
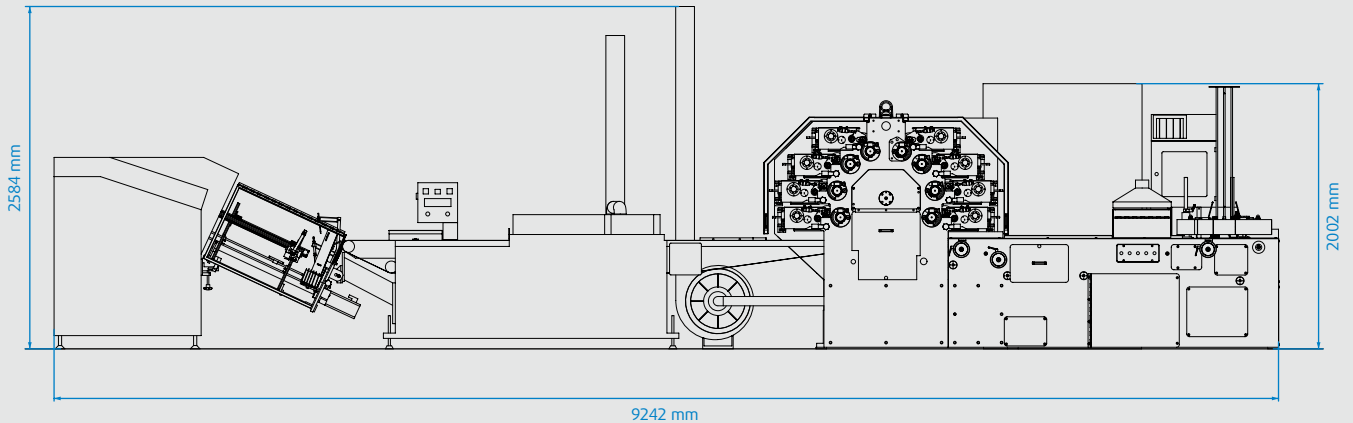

Our comprehensive service portfolio ensures you get the best out of your machine at all times. By offering regular maintenance, a hotline service, remote maintenance, and operator and process optimization training, we help you cut costs and improve productivity. We can also offer all the consumables you need to ensure a high-quality print result. Our own well-stocked spare parts store ensures quick part replacement if anything should go wrong at any time. Just ask for our service brochure.

Technical data	DDM 160
Round lids:	
Min./max. rim diameter:	50-190 mm
Polygonal lids:	
Min. rim dimension:	50 x 50 mm
Max. rim dimension:	185 x 210 mm
Min./max. lid height:	5/25 mm
Max. dimensions of print area:	150 x 185 mm
Available on request: For round lids	Max. Ø 150 mm
Max. printing speed (up to lids/h):	
Standard design	30000/h
SPIN ROD design	36000/h
Weight of main machine:	~5800 kg

Polytype AG
26, route de la Glâne
CH-1701 Fribourg/Switzerland

Phone +41 26 426 11 11

info@polytype.com
www.polytype.com

SWITZERLAND

WIFAG-Polytype Holding AG
Fribourg/Switzerland

Polytype AG
Fribourg/Switzerland

AMERICA

Polytype America Corp.
Lincoln Park, NJ/USA

ASIA

Polytype Asia Pacific Co., Ltd.
Chachoengsao/Thailand

Wifag-Polytype India
Marketing Private Ltd.
New Delhi/India