

BDM 301 R6/R9 – keeps on running

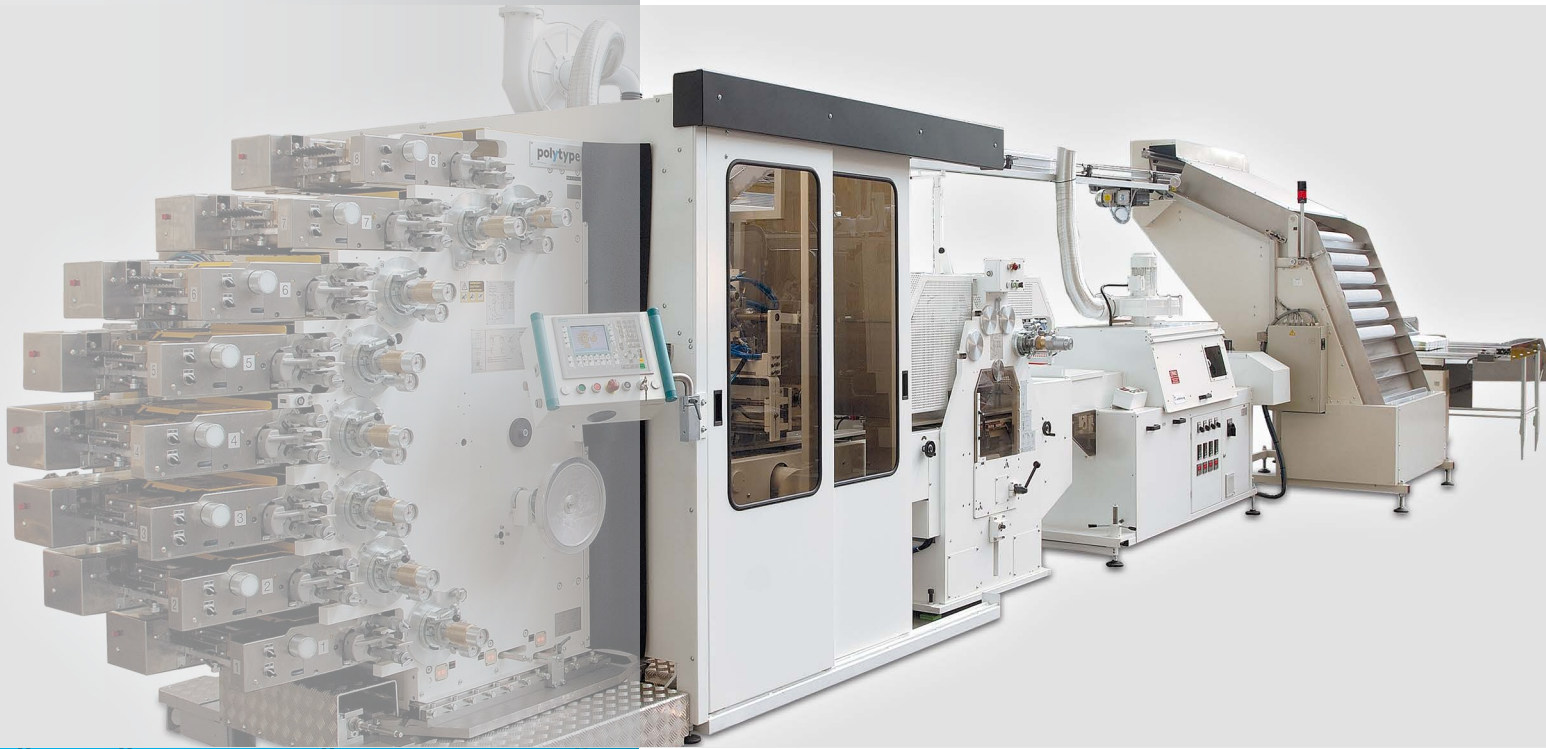

Dry offset cup printing system
for square cups

- // Wide variety of shapes
- // High production efficiency
- // Straightforward printing with UV inks
- // Simple operation and maintenance
- // Excellent print quality

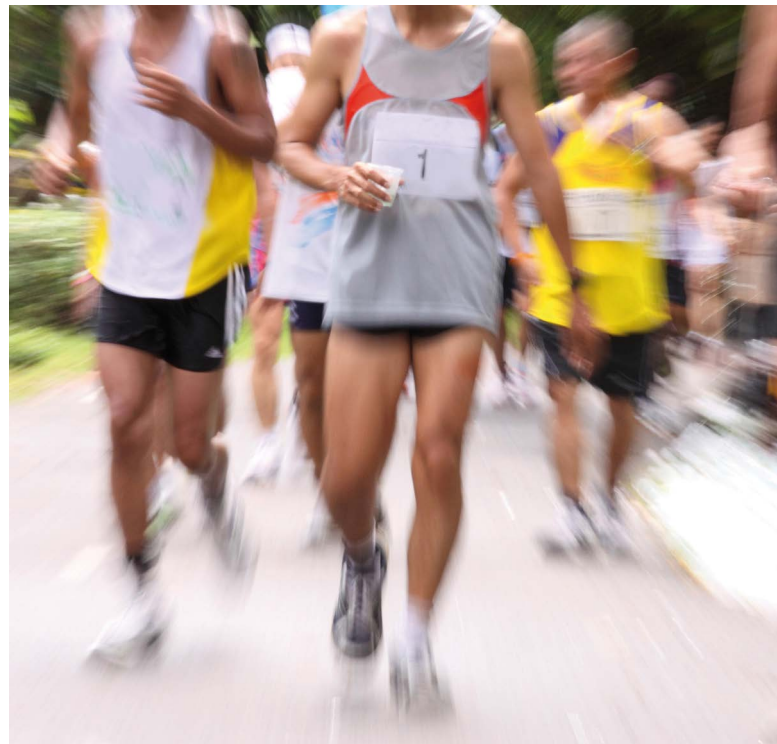

//polytype is a world-leading manufacturer of systems for direct printing of plastic cups and lids. //polytype machines combine innovative technology with extremely high reliability and user-friendly operation. Its international customers appreciate the modular expansion options of the machines.

//polytype is part of the Swiss wifag//polytype Group, which operates globally and has branches in Switzerland, Germany, Bulgaria, USA and Thailand. This alliance gives //polytype access to a broad technology base and guarantees a global and professional partnership for your success.

If you are looking for a printing system for square cups with maximum production efficiency, then the //polytype BDM 301-R6/R9 is the machine for you. The system ensures high throughput, extremely fast changeover times and outstanding print quality. It is the ideal machine for your requirements.

Rounding off round designs – your motif on any shape

The //polytype BDM 301 is well-established on the market and stands for outstanding print performance, reliability and low maintenance outlay. The machine has recently been enhanced with additional functions, such as automatic washing and a kit for fast changeovers so customers can achieve even higher production efficiency.

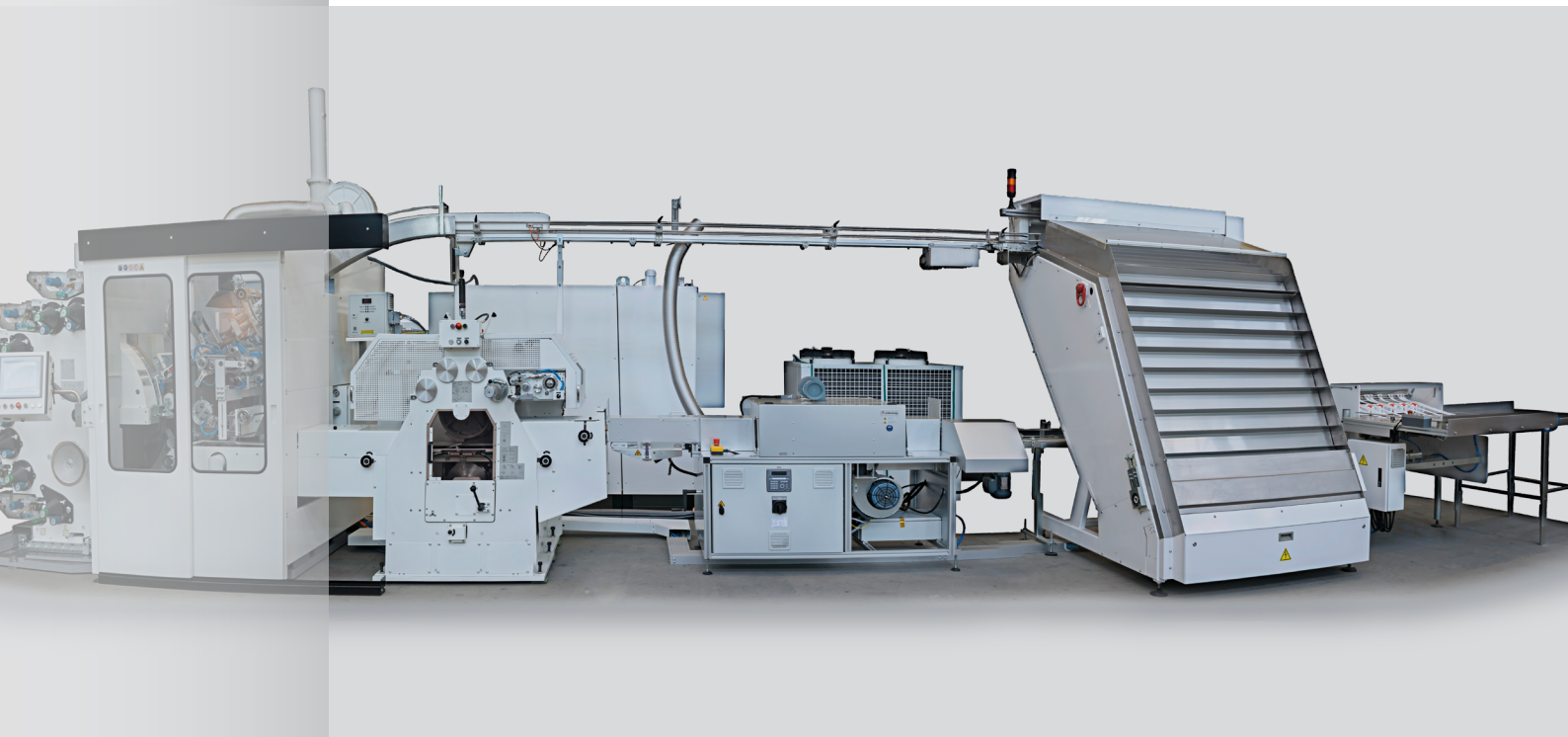

Available in a range of configurations, the //polytype BDM 301 can help optimize production workflows and area usage.

The dry offset cup printing system //polytype BDM 301 for square or oval containers is available with 6, 7 or 8 inking units. The machine is connected to an automatic elevator system that transports the cups to the transfer system. From here, the rectangular, oval and/or flat containers are fed into the printing machine.

The pre-treatment system ensures optimum surface tension across the container (including the bottom) and can be printed with up to 4 colors. The machine software precisely tracks the position of each container within the print process through to the horizontal or vertical stacker.

- // Print/inking units (up to 8 colors) for optimum print quality
- // Mandrel drive at printing station
- // Five independent vacuum circuits controlled via PLC
- // Simple changeover with memory bank for reference data

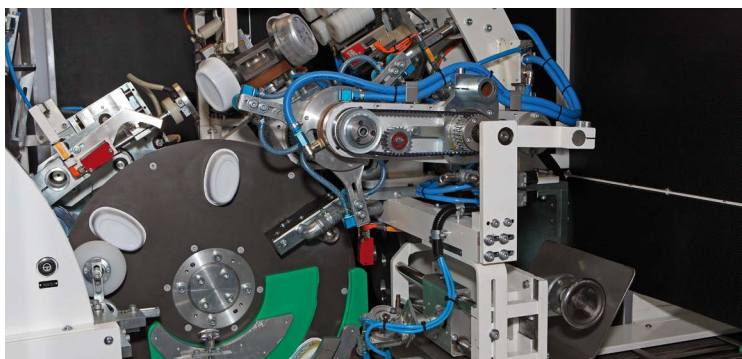

The //polytype BDM 301 is equipped with cup feeding with worm infeed. Corona pre-treatment is split between two separate stations - one for the side wall and one for the bottom. Transfer, cup positioning before and after printing, and universal cup take-off are included as standard.

Hinged horizontally and equipped with an ink agitator, the inking units deliver optimum full-area and halftone print results. The inking units are equipped with an auxiliary drive for ease of washing and pre-inking.

The //polytype BDM 301 has a 1-4 color base printing unit with individually hinged inking units. It is equipped with a separate drive for washing and pre-inking the rollers. The spare parts for the printing plate cylinder and inking units are identical to those used in the //polytype DDM 160 lid printing machine.

The UV curing system has horizontally arranged lamps that can be adjusted individually. It is fitted with the latest generation control system with electronic ballast.

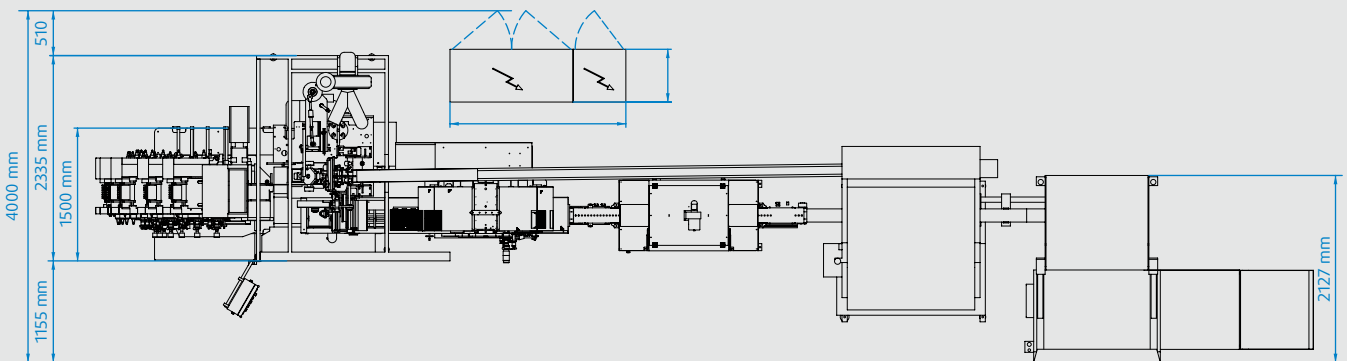
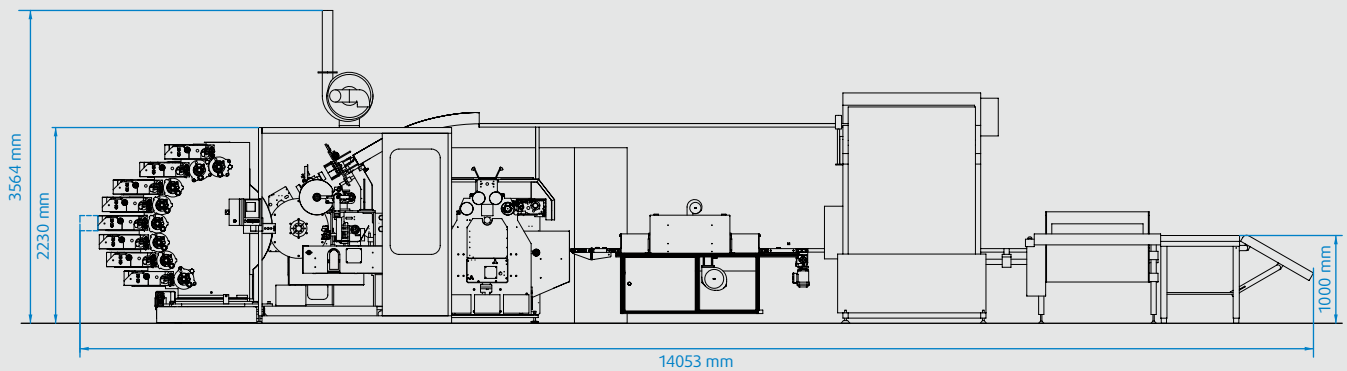

Our comprehensive service portfolio ensures you get the best out of your machine at all times. By offering regular maintenance, a hotline service, remote maintenance, and operator and process optimization training, we help you cut costs and improve productivity. We can also offer all the consumables you need to ensure a high-quality print result. Our own well-stocked spare parts store ensures quick part replacement if anything should go wrong at any time. Just ask for our service brochure.

Technical data	BDM 301-R
Min./max. cup height:	30-125 mm
Min. cup rim dimensions:	60 x 85 mm
Max. cup rim dimensions:	135 x 180 mm
Max. print height:	145 mm
Max. print length:	417-520 mm
Min./max. taper:	2-10°
Max. printing speed:	Up to 9000 pcs/h
Weight of main machine: 6 colors	~ 6000 kg

Polytype AG
26, route de la Glâne
CH-1701 Fribourg/Switzerland

Phone +41 26 426 11 11

info@polytype.com
www.polytype.com

SWITZERLAND

WIFAG-Polytype Holding AG
Fribourg/Switzerland

Polytype AG
Fribourg/Switzerland

AMERICA

Polytype America Corp.
Lincoln Park, NJ/USA

ASIA

Polytype Asia Pacific Co., Ltd.
Chachoengsao/Thailand

Wifag-Polytype India
Marketing Private Ltd.
New Delhi/India